

Physics I

010

03/Nov/2010 08.30am - 11.30am

REPUBLIC OF RWANDA

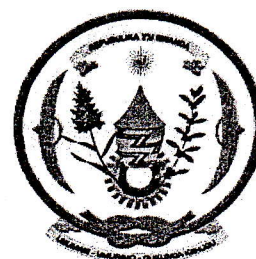

RWANDA EDUCATION BOARD

ORDINARY LEVEL NATIONAL EXAMINATIONS 2010

SUBJECT : PHYSICS I

DURATION : 3 HOURS

INSTRUCTIONS:

This paper consists **THREE** sections A, B and C.

Attempt **all** questions in section A. **(55 marks)**

Answer **any three** questions in section B. **(30 marks)**

Answer **only one** question in section C. **(15 marks)**

You may use a calculator and a mathematical instrument.

SECTION A. ATTEMPT ALL QUESTIONS IN THIS SECTION**(55 marks)**

1. Explain what is meant by average speed. State the unit of average speed. **(3 marks)**
2. A force of 25N acts on a mass of 5kg starting from rest. Find the acceleration. **(3 marks)**
3. What is the difference between mass and weight? State the unit of each quantity. **(4 marks)**
4. Draw a cone
 - a) in a stable equilibrium
 - b) in unstable equilibrium
 - c) in a neutral equilibrium**(3 marks)**
5. Calculate the power of a pump which can lift 300kg of water through a vertical height of 8m in 10s, $g = 10 \text{ m/s}^2$. **(3 marks)**
6. a) What is meant by the term density of body? **(2 marks)**
b) A body has a volume of 15 cm^3 and a mass of 27g. What is the density? Give the answer in kg/m^3 . **(3 marks)**
7. The diagram below shows a balancing uniform rod.

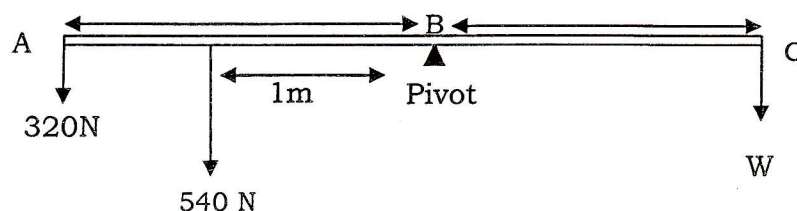

- Calculate the force W. **(4 marks)**
8. Show how a ray of light from the air passes through a glass block and explain why the ray of light behaves as you have shown in your diagram. **(5 marks)**
 9. Draw an electric circuit composed of a dry cell, connectors, a resistor, ammeter and voltmeter to read the voltage across the resistor. **(4 marks)**
 10. A student dropped iron filings into a sugar bowl by accident. Explain how sugar can be separated from the mixture. **(3 marks)**
 11. a) List the energy changes which occur when a torch is switched on. **(2 marks)**
b) Which are the other sources of electricity other than hydro electric power in Rwanda? **(3 marks)**
 12. Two cells each having an e.m.f of 1.5V and internal resistances of 2Ω are connected
 - a) In parallel
 - b) In seriesFind the current in each case when the cells are connected to a 1Ω resistor. **(4 marks)**
 13. a) State Archimedes' principle. **(2 marks)**
b) A piece of metal is weighed
 - i) in air
 - ii) fully submerged in water
 - iii) fully submerged in a salt solutionThe result obtained, but not in correct order were 6N, 5N and 8N. What was obtained for b (i), b (ii) and b (iii)? **(3 marks)**
 14. Explain how heat is transferred in water. **(4 marks)**

SECTION B: Answer any three questions**(30 marks)**

15. a) Define the term specific heat capacity of a substance. **(3 marks)**
b) A piece of aluminium of mass 600g is heated from 25°C to 100°C. How much heat is supplied if the specific heat capacity of aluminium is 900J/kg. What is the heat capacity of this metal? **(7 marks)**
16. a) What is meant by;
i. Potential energy? **(2 marks)**
ii. Kinetic energy? **(2 marks)**
b) An orange of mass 80g falls from a tree 2m high above the ground. Calculate the potential energy of the orange before it falls off the tree. Find the kinetic energy of the orange as it hits the ground. **(6 marks)**
17. a) Distinguish between a converging lens and a diverging lens. **(3 marks)**
b) What is meant by the term focal point of a lens? **(1 mark)**
c) An object 1m tall stands vertically on the principal axis of a converging lens of focal length 4cm. Determine the nature of the image if the object is 8cm from the optical center of the lens. **(6 marks)**
18. a) Which instrument would you use to measure atmospheric pressure? **(1 mark)**
b) With aid of a diagram show and explain that air of the atmosphere exerts force. **(7 marks)**
c) Calculate the pressure exerted by water at 10m below the surface of water in a lake. ($g = 10\text{N/kg}$ and density is 1000 kg/m^3) **(2 marks)**
19. A car of mass 15000kg travelling at 72km/hr is brought to rest in 5s. Find:
a) the average deceleration **(6 marks)**
b) the average breaking force. **(2 marks)**
c) the distance moved during deceleration. **(3 marks)**

SECTION C: Attempt only one question.**(15 marks)**

20. a) Draw a labeled electric diagram which you can use to determine the unknown resistor in a circuit. **(4 marks)**
b) A student carried out an experiment to determine the resistance of a conductor. The table below shows the results obtained:

| Potential difference/V | Current/A |
|------------------------|-----------|
| 1.2 | 0.6 |
| 2.2 | 1.1 |
| 4.0 | 2.0 |
| 6.4 | 3.2 |

- i. Plot a graph (potential difference along the Y-axis and current along the X-axis) **(7 marks)**
ii. What law may be determined from the graph? **(1 mark)**
iii. Find the resistance of the conductor from the graph. **(3 marks)**
21. A student carried out an experiment to determine the density of a liquid. Different masses of the liquid were measured and their respective volumes. The table below shows results obtained.

| mass/g | volume/A |
|--------|----------|
| 4 | 5 |
| 8 | 10 |
| 12 | 15 |
| 16 | 20 |
| 20 | 25 |
| 24 | 30 |

- a) Plot a graph of mass (Y-axis) against volume (X-axis). (9 marks)
- b) Does the graph start from the origin? Explain your answer. (4 marks)
- c) Determine the density of the liquid from the graph. Show on the graph how you get your answer. (2 marks)

END.

ANSWERS TO ORDINARY LEVEL PHYSICS PAPER 2010

SECTION A:

1. The speed of a car keeps on changing at different instants, it is never constant, so average speed is that which is obtained when the total distance covered in any direction divided by the total time taken to cover the distance.

Or $v = \frac{d}{t}$ where v is the average speed, d is total distance covered and t is time taken to cover the distance. The unit for average speed is m/s.

2. Data and unknown: $F = 25\text{N}$, $m = 5\text{kg}$, $a = ?$

Using Newton's second law: $F = ma \Leftrightarrow a = \frac{F}{m} = \frac{25}{5} = 5\text{m/s}^2$

- 3.
- | Mass | Weight |
|--------------------------------|--|
| - Is always the same | - Change with altitude and location |
| - Is a scalar quantity | - Is a vector quantity |
| - Quantity of matter in a body | - Is a force of gravity acting on a body |
| - Is measured in kg | - Is measured in Newton |
| - Is measured by a balance. | - Is measured by a Newton balance |

4. a), b) and c)



5. Work done: $W = mgh = 300 \times 10 \times 8 = 24000\text{J}$

$$\text{Power: } P = \frac{W}{t} = \frac{24000}{10} = 2400\text{W}$$

6. a) Density of a body is the quantity of matter in a body or $\rho = \frac{m}{V}$ where ρ = is density, m is mass and V volume. The unit of density is kg/m^3 .

- b) Data: $m = 27\text{g} = 27 \times 10^{-3}\text{kg}$, $V = 15\text{cm}^3 = 15 \times 10^{-6}\text{m}^3$

$$\rho = \frac{m}{V} = \frac{27 \times 10^{-3}}{15 \times 10^{-6}} = 1800\text{kg/m}^3$$

7. Anticlockwise moment = clockwise moment

$$320 \times 3 + 540 \times 1 = W \times 3 \Rightarrow W = 500\text{N}$$

8.

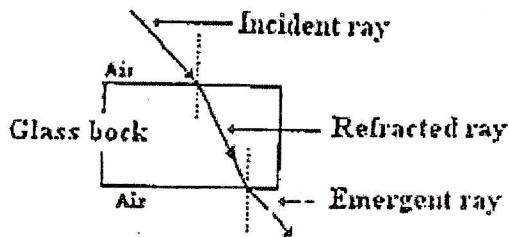

As light enters the glass block, its speed changes hence the direction changes so is the case when the refracted emerges from the block to the air.

9. Note the signs on the Ammeter and Voltmeter

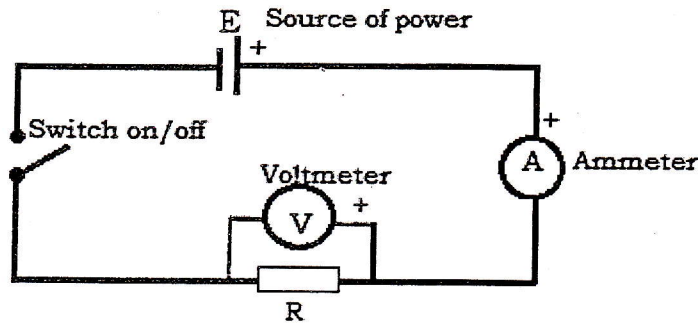

10. Iron fillings are attracted by a magnet while sugar is not attracted by a magnet. The magnet is used to pick the iron fillings from the mixture by holding the magnet close to the mixture.

11. a) mechanical energy, chemical energy, electrical energy, heat energy and light energy.
b) Generators, solar, batteries etc.

12. a) In parallel

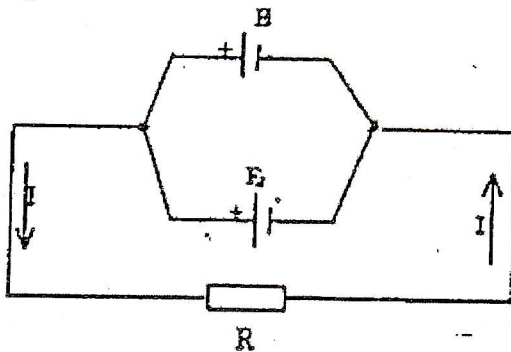

$$R_{eq} = r_{eq} + R = \frac{r_1 r_2}{r_1 + r_2} + R = \frac{2 \times 2}{2 + 2} + 1 = 2\Omega$$

b) In series

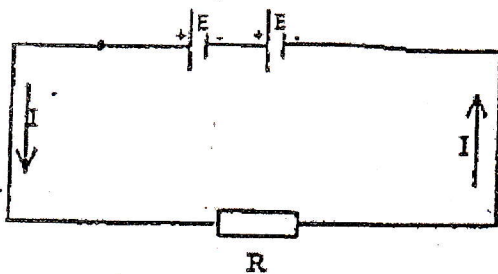

$$R_{eq} = r_{eq} + R = r_1 + r_2 + R = 2 + 2 + 1 = 5\Omega$$

$$I = \frac{E}{R_{eq}} = \frac{1.5}{5} = 0.6\text{A}$$

13. a) According to Archimedes' principle, "Any non-porous object that is completely or partially submerged in a fluid at rest is acted on by an upward (or buoyant) force. The magnitude of this force is equal to the weight of the fluid displaced by the object;
 $B = W_f = mfg = \rho fgV_{displaced}$. The volume of fluid displaced is equal to the volume of the portion of the object submerged"

b) i) 8N, ii) 6N, iii) 5N

14. Heat travels through water by convection method. Heat is applied under the container of water. Water at the bottom becomes hot and its density reduces hence rises to the top of the container.

The denser cold water at the top goes down to the bottom where it is also heated. This water also becomes hot and rises creating streams of warm water called convection currents.

Or

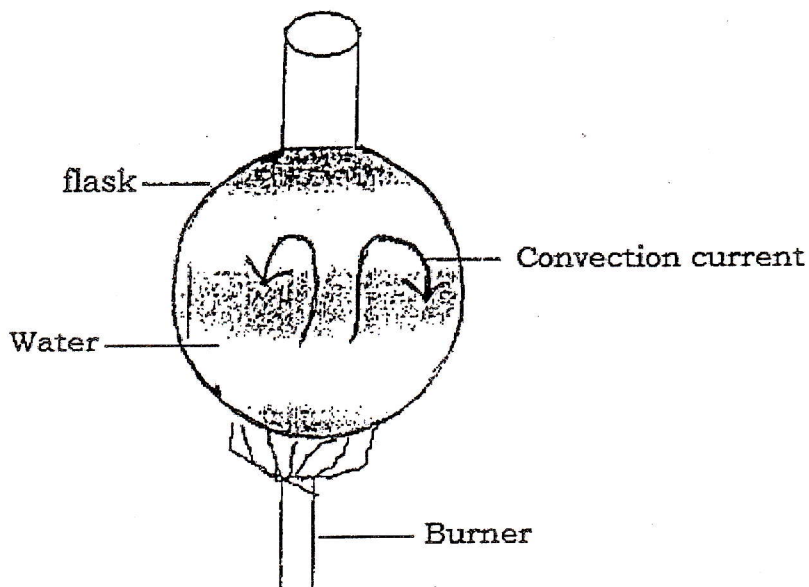

SECTION B

15. a) The specific heat capacity is the quantity of heat required to raise the temperature of 1Kg of a substance through 1°C or 1K. Its unit: J/kg°C J/KgK

b) Data $m = 600g = 0.6kg$ $\Delta t = 100^\circ C - 25^\circ C = 75^\circ C$ $C = 900J / kgK$

Heat applied: $Q = mC\Delta t = 0.6 \times 900 \times 75 = 40500J$

Heat capacity: $\mu = \frac{Q}{\Delta t} = mc = 0.6 \times 900 = 540J/K$

16. a) i) Potential energy is the energy possessed by the body because of its position. E.g. a body above the earth's surface has potential energy stored in the form of gravitational potential energy. A spring wound up has potential energy because of its strained condition

ii) Kinetic energy is that energy possessed by a body because of its motion.

b) Data: $m = 80g = 0.08kg$ $g = 10m/s^2$ $h = 2m$

Potential energy: $P.E = mgh = 0.08 \times 10 \times 2 = 1.6J$

Kinetic energy = Potential energy at the ground

$K.E = mgh = 0.08 \times 10 \times 2 = 1.6J$

17. a) **A converging lens**

Parallel incident rays to the lens meet at a point

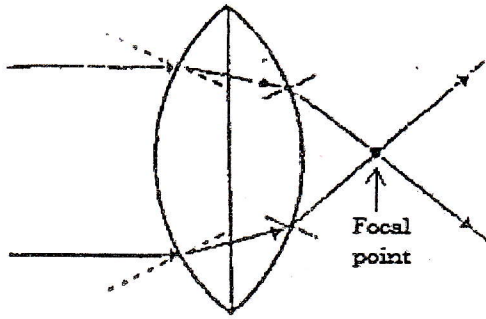

A diverging lens

Parallel incident rays to the lens diverge as they emerge out of the lens

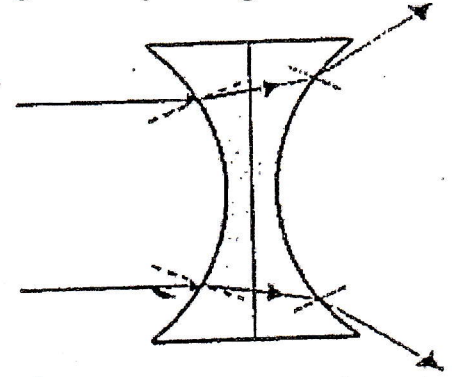

b) Focal point of a lens is a point where rays refracted by a lens meet. In convex lens the focal point is real and in concave lens is virtual.

c) Image is beyond 2F, real, inverted and larger than object 2cm, see graph below:

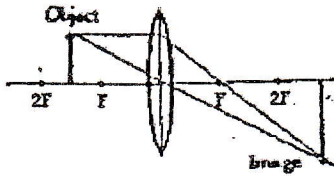

$$\frac{1}{p} = \frac{1}{q} = \frac{1}{f} \Rightarrow q = \frac{fp}{p-f} = \frac{6 \times 4}{6-4} = 12\text{cm}$$

$$Y = -\frac{q}{p} = \frac{h^1}{h} \Leftrightarrow h^1 = \frac{qh}{p} = -\frac{12 \times 100}{6} = -200\text{cm}$$

18. a) Aneroid barometer.

b) Air of the atmosphere exerts force

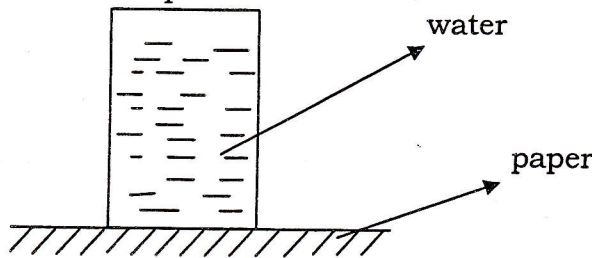

Fill a glass with water, cover the mouth of the glass using a paper. Gently turn the glass upside down. It will be observed that the paper remains covering the mouth of the glass without the water pouring. This is due to the force exerted by air in the atmosphere on the paper.

c) $h = 10\text{m}$, $g = 10\text{N/kg}$, $J = 1000\text{kg/m}^3$

$$\text{Pressure, } P = h\rho g = 10 \times 1000 \times 10\text{N/m}^2$$

$$P = 100,000\text{N/m}^2$$

19. a) mass, $m = 15000\text{kg}$, initial velocity, $u = \frac{72 \times 1000}{3600} = 20\text{m/s}$

Final velocity, $v = 0\text{m/s}$, $t = 5\text{s}$.

$$\text{Average deceleration, } a = \frac{V-U}{t} = \frac{0-20}{5} = -4\text{m/s}^2$$

Therefore, average deceleration = 4m/s^2

b) Average breaking force, $F = ma = 15000 \times 4 = 60000\text{N}$

17. a) **A converging lens**

Parallel incident rays to the lens meet at a point

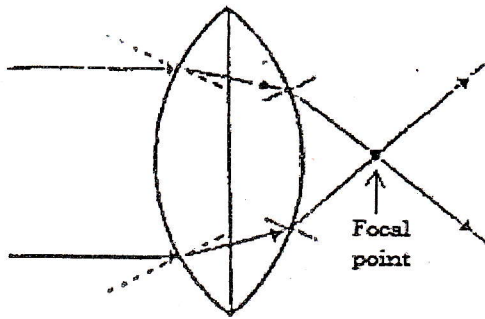

A diverging lens

Parallel incident rays to the lens diverge as they emerge out of the lens

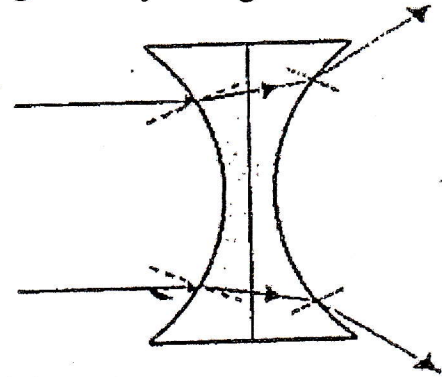

b) Focal point of a lens is a point where rays refracted by a lens meet. In convex lens the focal point is real and in concave lens is virtual.

c) Image is beyond 2F, real, inverted and larger than object 2cm, see graph below:

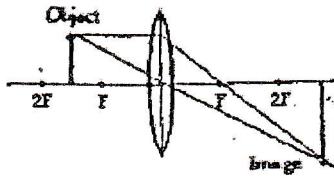

$$\frac{1}{p} = \frac{1}{q} = \frac{1}{f} \Rightarrow q = \frac{fp}{p-f} = \frac{6 \times 4}{6-4} = 12\text{cm}$$

$$Y = -\frac{q}{p} = \frac{h^1}{h} \Leftrightarrow h^1 = \frac{qh}{p} = -\frac{12 \times 100}{6} = -200\text{cm}$$

18. a) Aneroid barometer.

b) Air of the atmosphere exerts force

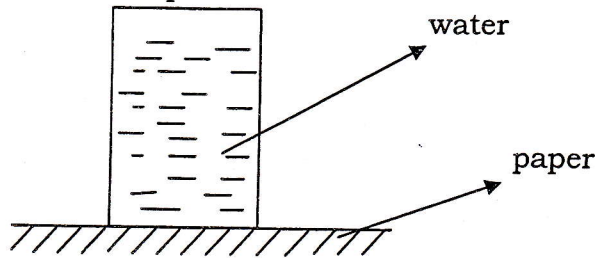

Fill a glass with water, cover the mouth of the glass using a paper. Gently turn the glass upside down. It will be observed that the paper remains covering the mouth of the glass without the water pouring. This is due to the force exerted by air in the atmosphere on the paper.

c) $h = 10\text{m}$, $g = 10\text{N/kg}$, $J = 1000\text{kg/m}^3$

$$\text{Pressure, } P = h\rho g = 10 \times 1000 \times 10\text{N/m}^2$$

$$P = 100,000\text{N/m}^2$$

19. a) mass, $m = 15000\text{kg}$, initial velocity, $u = \frac{72 \times 1000}{3600} = 20\text{m/s}$

Final velocity, $v = 0\text{m/s}$, $t = 5\text{s}$.

$$\text{Average deceleration, } a = \frac{V-U}{t} = \frac{0-20}{5} = -4\text{m/s}^2$$

Therefore, average deceleration = 4m/s^2

b) Average breaking force, $F = ma = 15000 \times 4 = 6000\text{N}$

c) Distance moved during deceleration.

$$s = ut + \frac{1}{2} at^2.$$

$$20 \times 5 + \frac{1}{2} \times -4 \times 5^2 = 50\text{m}$$

Or Distance = Average velocity \times time

$$= 10 \times 5 = 50\text{m}$$

SECTION C

20. a) Labeled electric diagram to determine the unknown resistor in a circuit.

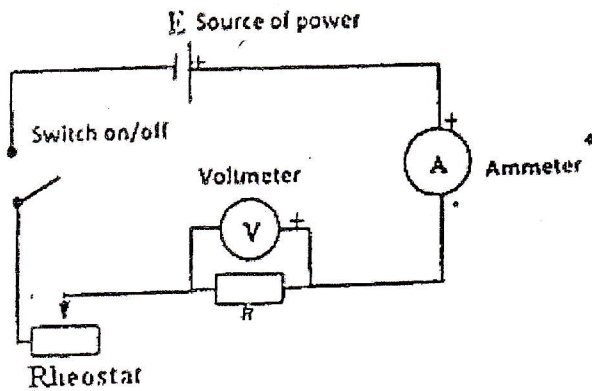

a) i)

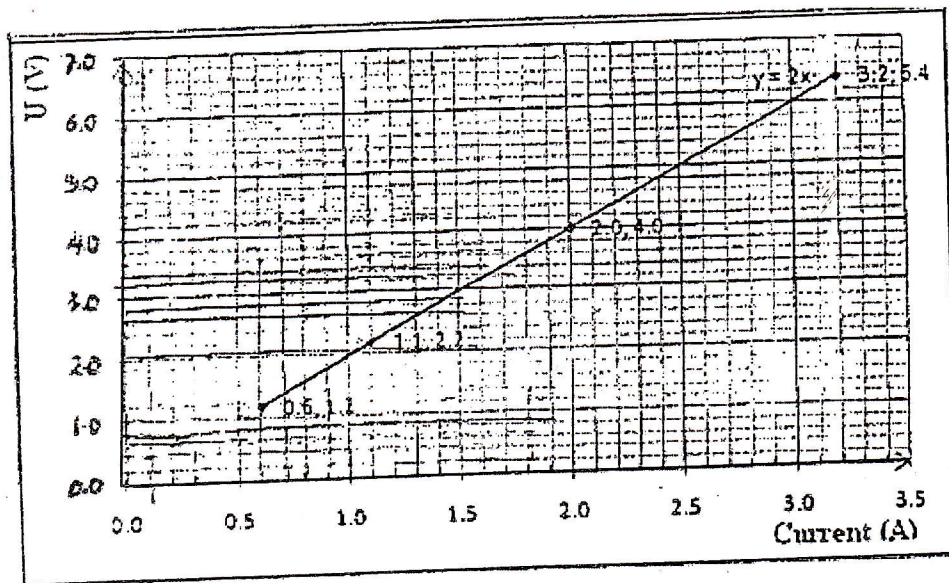

ii) Ohm's law.

iii) Increase in V: $\Delta V = 6.4 - 1.0 = 5.4\text{V}$

Increase in I: $\Delta I = 3.2 - 0.5 = 2.7$

$$\text{Resistance: } R = \frac{\Delta V}{\Delta I} = \frac{5.4}{2.7} = 2\Omega$$

21. a)

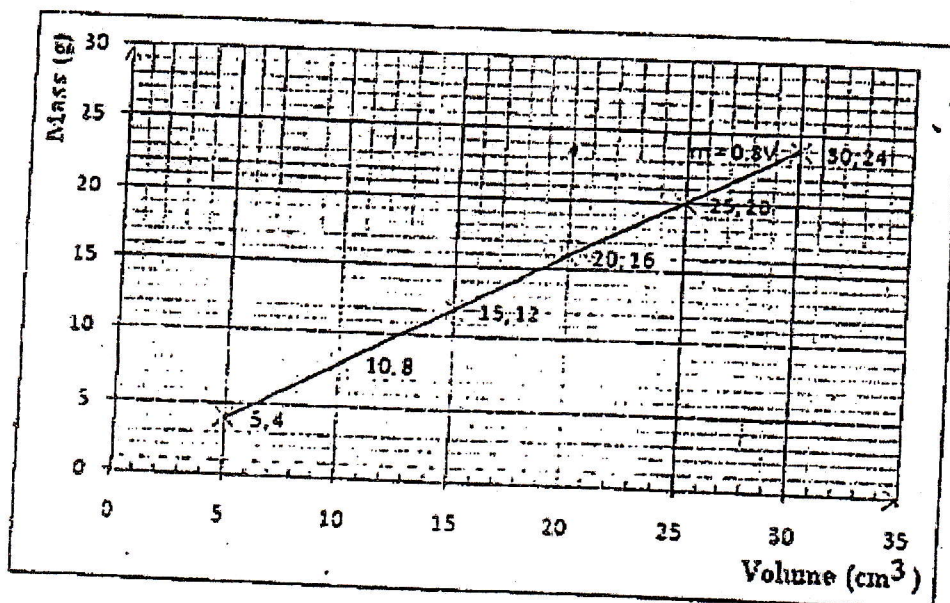

b) The graph should not go through the origin, it is meaningless. Zero mass has zero volume and zero divided by zero is meaningless.

c) Density of the liquid = $\frac{\Delta m}{\Delta v} = \frac{20g}{25cm^3} = 0.8g/cm^3$

END